

**|C|D|A|**

**hg7300.. - hg7320..**

# **Cooking Hobs**

Manual for Installation, Use and Maintenance



## Important

This appliance is designed and manufactured solely for the cooking of domestic (household) food and is not suitable for any non domestic application and therefore should not be used in a commercial environment.

The appliance guarantee will be void if the appliance is used within a non domestic environment i.e. a semi commercial, commercial or communal environment.

These instructions are only valid for those countries whose identification symbol appears on the cover of the instruction booklet and on the appliance.

The CDA Group Ltd cannot be held responsible for injuries or losses caused by incorrect use or installation of this product. Please note that CDA reserve the right to invalidate the guarantee supplied with this product following incorrect installation or misuse of the appliance.

### Appliance Information:

Please enter the details on the appliance rating plate below for reference, to assist CDA Customer Care in the event of a fault with your appliance and to register your appliance for guarantee purposes.

Appliance Model	<input type="text"/>
-----------------	----------------------

Serial Number	<input type="text"/>
---------------	----------------------

### Declaration of CE Conformity

This hob (Class 3) has been designed for use only as a cooking appliance. Any other use (e.g. heating rooms) should be considered incorrect and therefore dangerous.

This hob has been designed, constructed and put on to the market in conformity with:

- Safety requirements of EU Directive "Gas" 2009/142/EC;
- Safety requirements of EU Directive "Low Voltage" 2006/95/EC;
- Protection requirements of EU Directive "EMC" 2004/108/EC;
- Requirements of EU Directive 93/68/EEC;
- Requirements of EU Directive 2011/65/EU.

## IMPORTANT SAFETY PRECAUTIONS AND RECOMMENDATIONS

**IMPORTANT: This appliance is designed and manufactured solely for the cooking of domestic (household) food and is not suitable for any non domestic application and therefore should not be used in a commercial environment.**

**The appliance guarantee will be void if the appliance is used within a non domestic environment i.e. a semi commercial, commercial or communal environment.**

**Read the instructions carefully before installing and using the appliance.**

- After having unpacked the appliance, check to ensure that it is not damaged.  
In case of doubt, do not use it and consult your supplier or a professionally qualified technician.
- Packing elements (i.e. plastic bags, polystyrene foam, nails, packing straps, etc.) should not be left around within easy reach of children, as these may cause serious injuries.
- Some appliances are supplied with a protective film on steel and aluminium parts. **This film must be removed before using the appliance.**
- **IMPORTANT:** The use of suitable protective clothing/gloves is recommended when handling or cleaning this appliance.
- Do not attempt to modify the technical characteristics of the appliance as this may become dangerous to use. The manufacturer declines all responsibility for any inconvenience resulting from the inobservance of this condition.
- **CAUTION:** this appliance must only be installed in a permanently ventilated room in compliance with the applicable regulations.
- Do not carry out cleaning or maintenance operations on the appliance without having previously disconnected it from the electric power supply.
- Do not use a steam cleaner because the moisture can get into the appliance thus make it unsafe.
- Do not touch the appliance with wet or damp hands (or feet).
- Do not use the appliance whilst in barefoot.

- If you should decide not to use this appliance any longer (or decide to substitute another model), before disposing of it, it is recommended that it be made inoperative in an appropriate manner in accordance to health and environmental protection regulations, ensuring in particular that all potentially hazardous parts be made harmless, especially in relation to children who could play with unused appliances.
- The various components of the appliance are recyclable. Dispose of them in accordance with the regulations in force in your country. If the appliance is to be scrapped, remove the power cord.
- After use, ensure that the knobs are in the off position.
- Children less than 8 years of age shall be kept away unless continuously supervised.
- This appliance can be used by children aged from 8 years and above and persons with reduced physical, sensory or mental capabilities or lack of experience and knowledge if they have been given supervision or instruction concerning use of the appliance in a safe way and understand the hazards involved. Children shall not play with the appliance. Cleaning and user maintenance shall not be made by children without supervision.
- The manufacturer declines all liability for injury to persons or damage to property caused by incorrect or improper use of the appliance.
- **WARNING:** During use the appliance and its accessible parts become hot; they remain hot for some time after use.
  - Care should be taken to avoid touching heating elements on the hob.
  - To avoid burns and scalds, young children should be kept away.
- Make sure that electrical cables connecting other appliances in the proximity of the cooktop cannot come into contact with the hob.
- **WARNING:** Unattended cooking on a hob with fat or oil can be dangerous and may result in fire. **NEVER** try to extinguish a fire with water, but switch off the appliance and then cover flame e.g. with a lid or a fire blanket.
- **WARNING:** Danger of fire: do not store items on the cooking surfaces.
- **WARNING:** When correctly installed, your product meets all safety requirements laid down for this type of product category. However special care should be taken around the underneath of the appliance as this area is not designed or intended to be touched and may contain sharp or rough edges, that may cause injury.

## Features and Technical Data

hg7320..

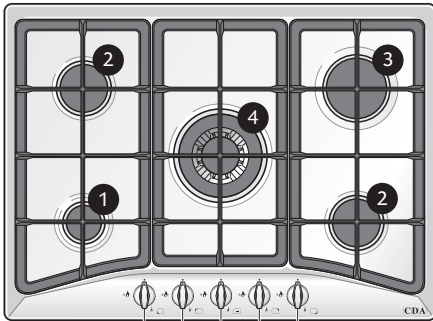

Fig. 1a

hg7300..

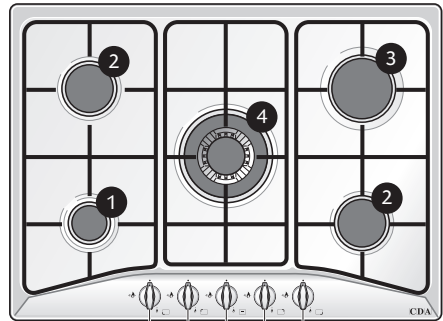

Fig. 1b

### Cooking Points

- 1. Auxiliary burner (A) - 1,00 kW
- 2. Semi-rapid burner (SR) - 1,75 kW
- 3. Rapid burner (R) - 3,00 kW
- 4. Triple ring burner (TR) - 3,50 kW

**This appliance is class 3**

### Control Panel

- 5. Auxiliary burner control knob (1)
- 6. Rear left semi-rapid burner control knob (2)
- 7. Triple ring burner control knob (4)
- 8. Rapid burner control knob (3)
- 9. Front right semi-rapid burner control knob (2)

### Note:

- The electric ignition is incorporated in the knobs.
- The appliance has a safety valve system fitted. The flow of gas will be stopped if and when the flame should accidentally go out.

### Caution:

- If the burner is accidentally extinguished, turn the gas off at the control knob and wait at least 1 minute before attempting to relight.
- Gas hobs produce heat and humidity in the environment in which they are installed. Ensure that the cooking area is well ventilated by opening the natural ventilation grilles or by installing an extractor hood connected to an outlet duct.
- If the hob is used for a prolonged time it may be necessary to provide further ventilation by opening a window or by increasing the suction power of the extractor hood (if fitted).

## How to Use the Hob

### Gas Burners

Gas flow to the burners is adjusted by turning the knobs (illustrated in fig. 2) which control the valves. Turning the knob so that the indicator line points to the symbols printed on the panel achieves the following functions:

– Symbol ● : Tap closed (burner off)

– Symbol  : High (maximum)

– Symbol  : Low (minimum)

- The maximum aperture position permits rapid boiling of liquids, whereas the minimum aperture position allows slower warming of food or maintaining boiling conditions of liquids.
- To reduce the gas flow to minimum, rotate the knob further anti-clockwise to point the indicator towards the small flame symbol.
- Other intermediate operating adjustments can be achieved by positioning the indicator between the maximum and minimum aperture positions, and never between the maximum aperture and closed positions.

### Caution!

**The cooking hob becomes very hot during operation. Keep children well out of reach.**

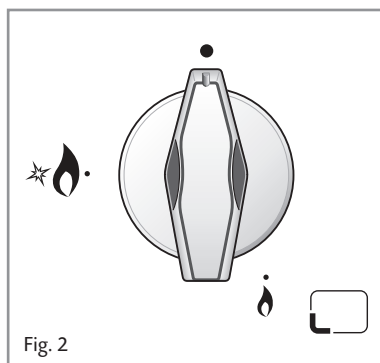

## Lighting Gas Burners

In order to light the burner, you must:

- 1 – Press in the corresponding knob and turn counter-clockwise (fig. 3) to the full flame position marked by the  symbol and hold the knob in until the flame has been lit.

In the case of a mains failure light the burner with a match or lighted taper.

- 2 – Wait about ten seconds after the gas lighting before releasing the knob (starting time for the valve).
- 3 – Adjust the gas valve to the desired power.

### Important

If the burner flame should go out for some reason, the safety valve will automatically stop the gas flow.

To re-light the burner, return the knob to the closed ● position, **wait for at least 1 minute** and then repeat the lighting procedure.

If your local gas supply makes it difficult to light the burner with the knob set to maximum, set the knob to minimum and repeat the operation.

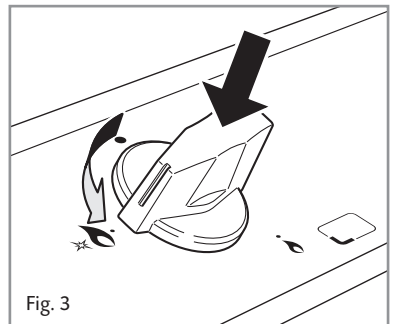

Fig. 3

## Choice of Burner

The symbols printed on the panel by the side of the knob indicate which burner you are controlling. Choose a suitable burner depending on the cookware diameter and capacity.

The pan diameter should be suitable for the burner power to make the most of the burner's high efficiency and not waste fuel.

A small pan does not boil more quickly on a large burner (fig. 4).

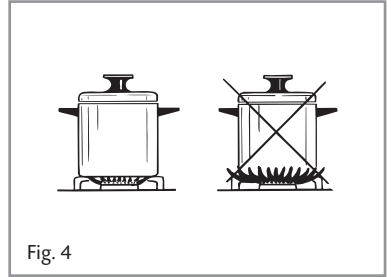

Burner Size	Minimum Pan Diameter (cm)	Maximum Pan Diameter (cm)
Auxiliary	12 <sup>(1)</sup>	14
Semi-Rapid	16	24 <sup>(2)</sup>
Rapid	24	26
Triple Ring	26	28
Wok <sup>(3)</sup>	-	36

(1) model hg7320.. minimum diameter 6 cm.

(2) front right burner, maximum diameter 22 cm.

(3) Wok pans have to be used only with the special grille fitted (see correct use of triple-ring burner).



## Correct use of Triple-Ring Burner

The flat-bottomed pans are to be placed directly onto the pan-support.

To use the WOK you need to place the proper stand in order to avoid any faulty operation of the triple-ring burner (Figs. 5a - 5b - 6a - 6b).

**Important:** The wok pan stand (fig. 5b - 6b) **MUST BE PLACED ONLY** over the pan-rest for the triple ring burner.

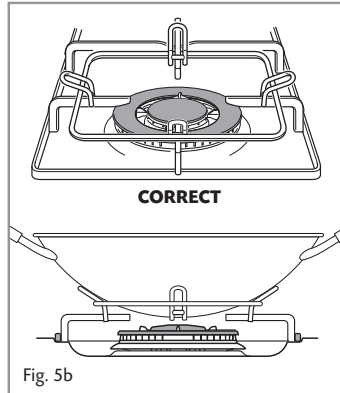
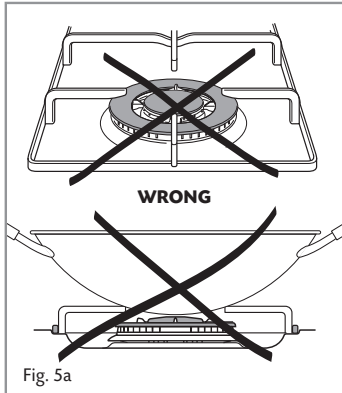

Model:  
**hg7300..**

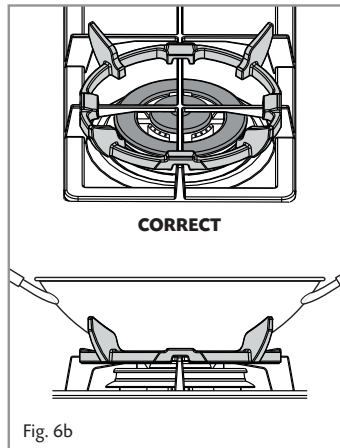
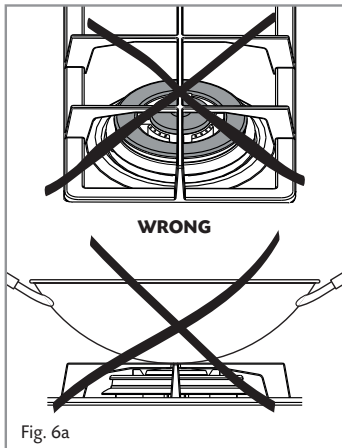

Model:  
**hg7320..**

## Cleaning and Maintenance

### General Tips

- Before cleaning the hob switch it off and wait for it to cool down.
  - Clean with a cloth, hot water and soap or liquid detergent.
  - Do not use products which are abrasive, corrosive or chlorine based.
  - Do not use steel pads.
  - Avoid using cleaning products with a chlorine or acidic base.
  - Do not leave acid or alkaline substances (vinegar, salt, lemon juice, etc.) on the hob.
  - **Steam cleaners must not be used when cleaning this appliance.**
- **Warning:** When correctly installed, your product meets all safety requirements laid down for this type of product category. However special care should be taken around the underneath of the appliance as this area is not designed or intended to be touched and may contain sharp or rough edges, that may cause injury.

### Enamelled Parts

- All the enamelled parts must be cleaned with a sponge and soapy water only or other non-abrasive products.
- Dry preferably with a soft cloth. If acid substances such as lemon juice, tomato conserve, vinegar etc. are left on the enamel for a long time they will etch it, making it opaque.

### Stainless Steel Surfaces

- Stainless steel parts should be rinsed with water and dried with a soft cloth.
- For persistent dirt, use specific non-abrasive products available commercially or a little hot vinegar.
- **Note:** regular use will cause discolouring around the burners, because of the high flame temperature.

### Control Knob

- The control knobs may be removed for cleaning but care should be taken not to damage the seal.

### Gas Taps

- Regular lubrication of the gas taps must only be performed by specialised engineers.
- If the gas taps are not working properly call the After-Sales Service.

## Burners and Grids

- These parts can be removed and cleaned with appropriate products.
- After cleaning, the burners and their flame spreaders must be well dried and correctly replaced.
- It is very important to check that the burner flame spreader and the cap have been correctly positioned. Failure to do so can cause serious problems.
- Check that the electrode "S" (figs. 7 - 9) is always clean to ensure trouble-free sparking.
- Check that the sensor "T" (figs. 7 - 9) next to each burner is always clean to ensure correct operation of the safety valves.
- Both the probe and ignition plug must be very carefully cleaned.
- **Note: To avoid damage to the electric ignition do not use it when the burners are not in place.**

## Correct Positioning of the Burners (Auxiliary, Semi-rapid and Rapid burners)

- It is very important to check that the burner flame spreader "F" and the cap "C" have been correctly positioned (see figs. 7 and 8). Failure to do so can cause serious problems.

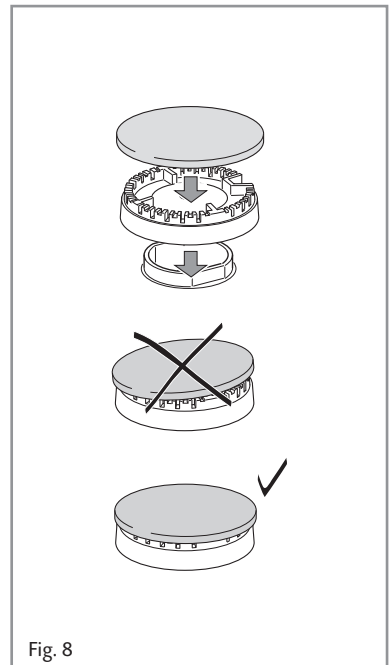
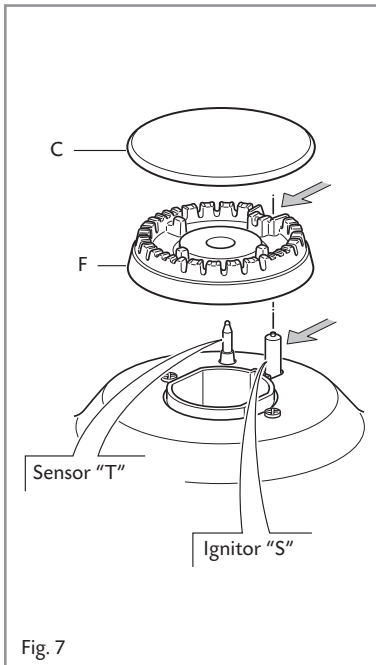

## Correct Position of Triple Ring Burner

The triple ring burner must be correctly positioned (see fig. 9); the burner ribs must be fitted in their housing as shown by the arrow.

The burner correctly positioned must not rotate (fig. 10).

Then position the cap "A" and the ring "B" (figs. 10 - 11)

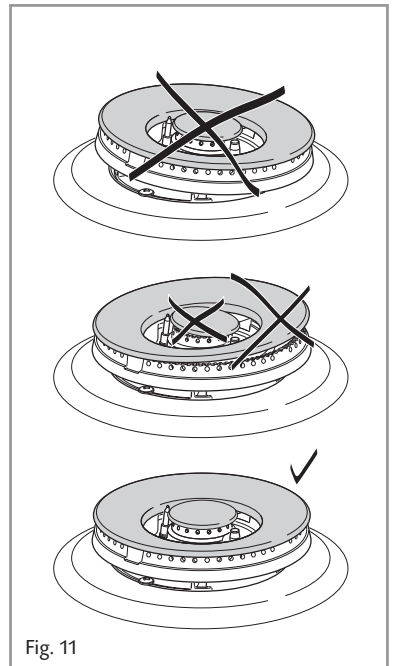
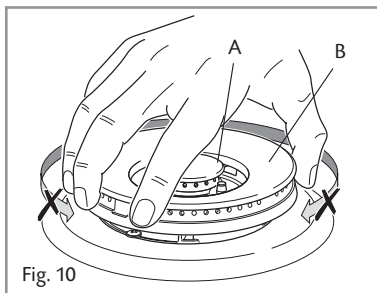
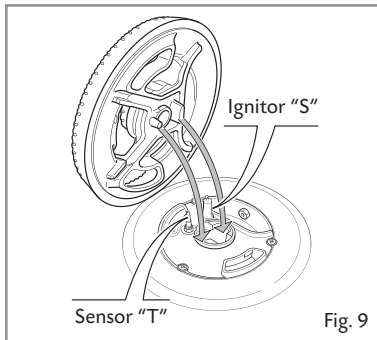

## TIPS FOR INSTALLATION

### Location

- The appliance may be installed in a kitchen, Kitchen/diner or a bed sitting room, but not in a room or space containing a bath or a shower.
- The appliance must not be installed in a bed-sit room of less than 20m<sup>3</sup>.
- The appliance is designed and approved for domestic use only and should not be installed in a commercial, semi commercial or communal environment.
- Your product will not be guaranteed if installed in any of the above environments and could affect any third party or public liability insurances you may have.
  
- This hob should only be installed by a **qualified installer**. Failure to observe this rule leads to cancellation of the guarantee.
- The appliance must be installed correctly, in compliance with the regulations in force and following the manufacturer's instructions.
- Any repair or maintenance must be performed with the appliance switched off.
- These appliances have been designed and manufactured to be fitted into heat-resistant units.
- These hobs are designed to be fitted into 600mm deep kitchen units.
- The unit walls must not be higher than the working surface and must withstand a temperature of 105°C above room temperature.
- Avoid installation near inflammable materials (e.g. curtains).

### Ventilation Requirements

- The appliance should be installed into a room or space with an air supply in accordance with BS 5440-2: 2000.
- For rooms with a volume of less than 5m<sup>3</sup> - permanent ventilation of 100cm<sup>2</sup> free area will be required.
- For rooms with a volume of between 5m<sup>3</sup> and 10m<sup>3</sup> a permanent ventilation of 50cm<sup>2</sup> free area will be required unless the room has a door which opens directly to the outside air in which case no permanent ventilation is required.
- For rooms with a volume greater than 10m<sup>3</sup> - no permanent ventilation is required.

#### **Important !**

**Regardless of room size, all rooms containing the appliance must have direct access to the outside air via an openable window or equivalent.**

- Where there are other fuel burning appliances in the same room, BS 5440-2: 2000 should be consulted to determine the correct amount of free area ventilation requirements.
- The above requirements allow also for use of a gas oven and grill but if there are other gas burning appliances in the same room, consult a qualified engineer.

# Installation

## Technical Information for the Installer

In order to install the hob into the kitchen fixture, a hole with the dimensions shown in fig. 12 has to be made, bearing in mind the following:

- Within the unit, between the bottom of the hob and the upper surface of a shelf there must be a clearance of at least 30mm.
- It is absolutely essential that you place a separator between the base of the hob and the built-in unit or the oven.
- The hob must be kept no less than 200mm away from any side wall (fig. 12).
- The hob must be installed at least 60mm from the wall.
- If a splashback is to be fitted it has to be fireproof and heat resistant; it is important to ensure that the gap between the edge of the hob and the splashback is at least 50mm. Refer to the instructions provided with your splashback for further information.
- There must be a distance of at least 650mm between the hob and any wall cupboard or extractor hood positioned immediately above (see fig. 14).
- If the hob is installed over a built-in oven, there must be a distance of at least 30mm between the two appliances. The two appliances should be connected to the gas supply with independent connections

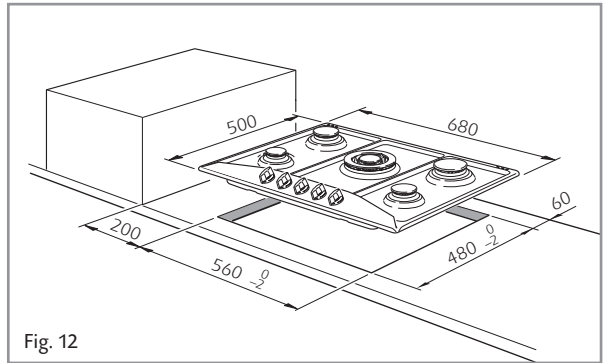

## Installation in Kitchen Cabinet with Door

It is recommended that a 30mm clearance be left between the cooktop and the fixture surface (fig. 13).

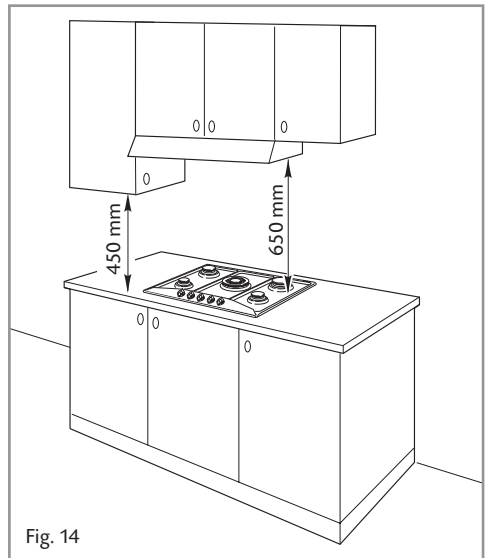
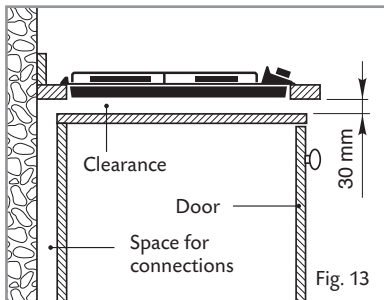

## Applying the Seals

- Turn the cooktop upside down.
- Spread the longer seal "A" around the left, rear and right sides as shown in figure 15a.
- With a cutter or a scissors cut the excess seal "C" and retain it for next use (figure 15b).
- Spread the seal "B" around the left, front and right edges of the cooktop as shown in figure 15c.
- Spread the seal "C" along the rear edge of the cooktop as shown in figure 15d. Making sure that the beginning and the end overlap at the seal "B" (see figure 15e).

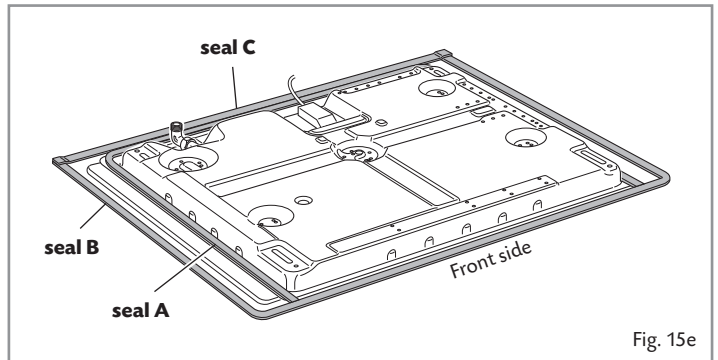
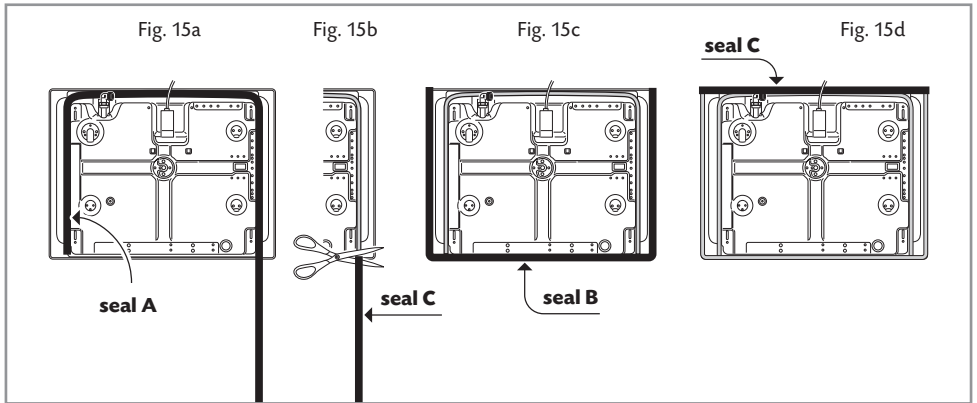

## Fastening the Installation Brackets

Each cooktop is provided with an installation kit including brackets and screws for fastening the top to fixture panels from 2 to 4 cm thick.

- Turn the cooktop upside down and fasten the brackets "F" and "R" to the appropriate socket holes, without tightening the screws "B" for the moment.
- Make sure that the brackets are fastened as shown in figures 16a, 16b and 16c.

## Fastening the Cooktop

- Insert the cooktop into the hole and position it correctly.
- Adjust the position of the brackets "F" and "R" and tighten screws "B" to block the cooktop firmly in position.
- With a sharp cutter or trimmer knife trim the excess sealing material around the edge of the cooktop.  
Take care not to damage the workbench.

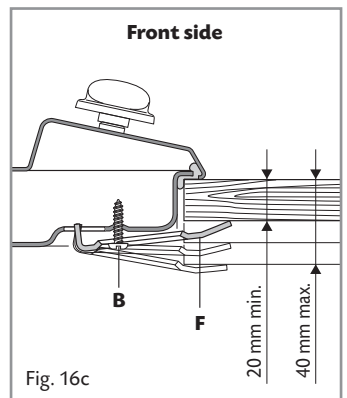
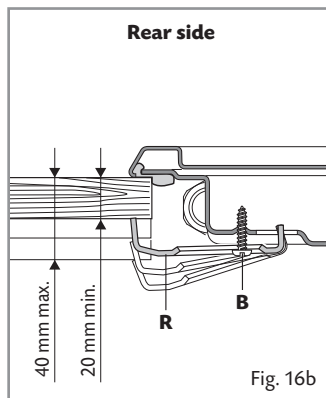
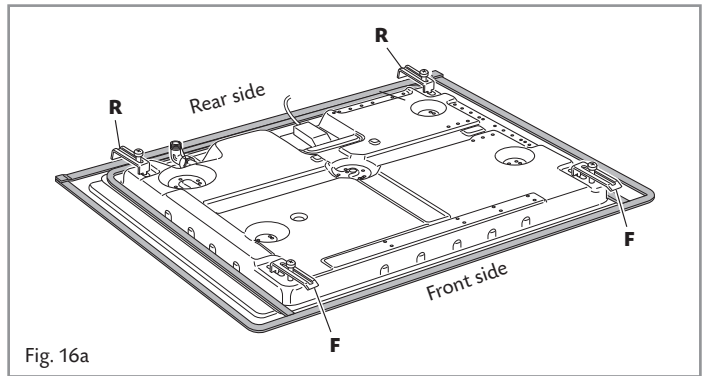



## Gas Supply Requirements

### Important Note

This appliance is supplied for use on NATURAL GAS or LPG (check the gas regulation label attached on the appliance).

- Appliances supplied for use on NATURAL GAS: they are adjusted for this gas only and cannot be used on any other gas (LPG) without modification. The appliances are manufactured for conversion to LPG.
- Appliances supplied for use on LPG: they are adjusted for this gas only and cannot be used on any other gas (NATURAL GAS) without modification. The appliances are manufactured for conversion to NATURAL GAS.

If the NATURAL GAS/LPG conversion kit is not supplied with the appliance this kit can be purchased by contacting the After-Sales Service.

### Installation and Service Regulations (United Kingdom Only)

This appliance must be installed and serviced only by a suitably qualified and registered person, and in accordance with the current editions of the following standards and regulations or other locally applicable regulations:

- Gas Safety (Installation and Use) Regulations
- Building Regulations
- British Standards
- Regulations for Electrical Installation

Installation and service of any gas product must be made by a suitably qualified person competent on the type of product being installed or serviced and holding a valid certificate of competence for the work being carried out. Currently the proof of competence is the Accredited Certification Scheme (ACS) or S/NVQ that has been aligned to the ACS.

It is also a requirement that all businesses or self employed installers are members of a class of person approved by the Health and Safety Executive.

Failure to install the appliance correctly could invalidate any manufacturers warranty and lead to prosecution under the above quoted regulation.

## Gas Connection

The installation of the gas appliance to Natural Gas or LP Gas must be carried out by a **suitably qualified and registered installer**. Installers shall take due account of the provisions of the relevant British Standards Code of Practice, the Gas Safety Regulations and the Building Standards (Scotland)(Consolidation) Regulations issued by the Scottish Development Department.

### Installation to Natural Gas

Installation to Natural Gas must conform to the Code of Practice, etc.

The supply pressure for Natural Gas is 20 mbar.

The installation must conform to the relevant British Standards.

### Installation to LP Gas

When operating on Butane gas a supply pressure of 28-30 mbar is required. When using Propane gas a supply pressure of 37 mbar is required.

The installation must conform to the relevant British Standards.

CDA are not legally able to provide any assistance in the installation of gas appliances except to suitably qualified and registered installers. Any suitably qualified and registered fitter requiring help must provide name, address and registration number.

Information supplied will be validated before help is provided.

### Warning:

**Only a suitably qualified and registered installer, also with technical knowledge of electricity should install the appliance. He should observe the Regulations and Codes of Practice governing such installation of gas appliances.**

**Note: It is recommended that the gas connection to the appliance is installed with a flexible connecting tube made to BS5386.**

### Notes:

- Flexible hoses can be used where the sited ambient temperature of the hose does not exceed 70°C. These hoses must be manufactured in accordance with BS669 part 1 and be of the correct construction for the type of gas being used.
- Gas hoses designed for natural gas **MUST NOT** be used for supplying LPG gas (LPG gas hoses can be identified by a either a red band or stripe on the rubber outer coating of the hose).  
The hose should not be crushed or trapped or be in contact with sharp or abrasive edges.

## Gas connection Cat: II 2H3+

The fitting (fig. 17) is made up of:

- 1 nut "A"
- 1 elbow fitting "C"
- gasket "F"

### Connection to the Gas Supply

- Be careful when flexible pipes are used that they do not come into contact with moving parts.
- To maintain the thickness of 3 cm, the hob is fitted with a channel to contain the connection pipe.
- The gas inlet union can be turned in the direction required after the elbow fitting "C" and nut "A" connection (figure 17) has been slackened (fig. 18).
- Never put it in the horizontal or vertical position.
- Never attempt to turn the elbow "C" without having first slackened off the relative lock nut "A".
- The gasket "F" (fig. 17) guarantees the seal of the gas connection. It is recommended that it be replaced whenever it shows even the slightest deformation or imperfection.
- **Using a suitable leak detection fluid solution (e.g. Rocol) check each gas connection one at a time by brushing the solution over the connection.**

**The presence of bubbles will indicate a leak. If there is a leak, tighten the fitting and then recheck for leaks.**

**IMPORTANT! Do not use a naked flame to test for leaks.**

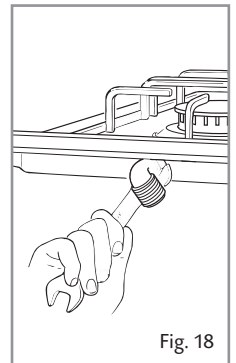
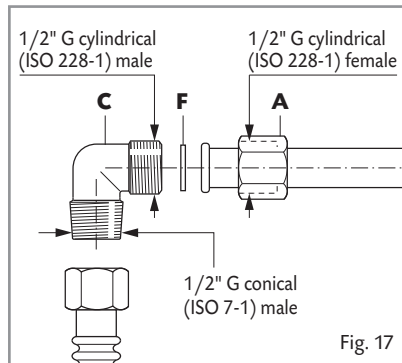

If installation is to be carried out using a flexible connector (to BS669), then the following points must be adhered to:

**Note:** The gas installation pipes and the final connection to the appliance connecting pipe shall be sufficient size to maintain the heat output of the appliance as specified under installation.

1. The appliance flexible connector should not be subject to undue forces, either in normal use whilst being connected or disconnected.
2. The appliance flexible connector should not be subject to excessive heat by direct exposure to flue products or by contact with hot surfaces.
3. The socket into which the plug of the appliance flexible connector fits should be permanently attached to a firmly fixed gas installation pipe and positioned such that the hose hangs freely downwards.
4. The appliance flexible connector should be positioned such that it will not suffer mechanical damage; eg abrasion from the surrounding kitchen furniture which may be moved in use, such as a door or drawer, or by being trapped by a stability device.
5. The plug-in connector should be accessible for disconnection after moving the appliance.

## Conversion to Natural Gas or LPG

### Replacing the Burner Injectors

If the NATURAL GAS/LPG conversion kit is not supplied with the appliance this kit can be purchased by contacting the After-Sales Service.

Choose the injectors to be replaced according to the table below.

The injector diameter, expressed in hundredths of a millimetre, is marked on the injector body.

To replace the injectors proceed as follows:

- Remove the pan supports, the burner caps and flame spreaders.
- Using a wrench, substitute the nozzle injectors "J" (Figs. 19 - 20) with those most suitable for the kind of gas for which it is to be used.

**The burners are made in such a way so as not to require regulation of the primary air.**

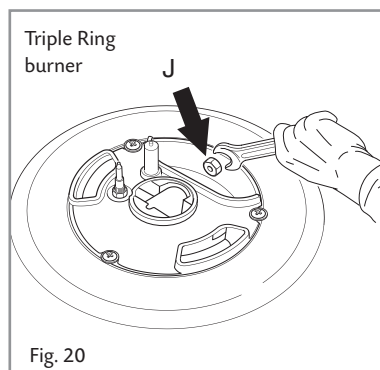
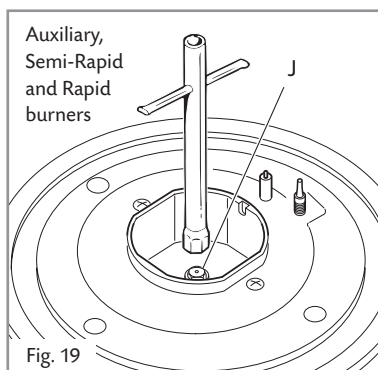

Table for the Choice of the Injectors			GB Cat: II 2H 3+	
Burners	Nominal Power kW	Reduced Power kW	G30 - 28-30 mbar G31 - 37 mbar	G20 - 20 mbar
			Ø Injector 1/100 mm	Ø Injector 1/100 mm
Auxiliary (A)	1,00	0,40	50	77
Semi-Rapid (SR)	1,75	0,45	66	101
Rapid (R)	3,00	0,75	87	129
Triple Ring (TR)	3,50	1,50	93	135

## Regulating the Burner Minimum Setting

When changing from one type of gas to another, the minimum tap output must also be correct, considering that in this position the flame must be about 4 mm long and must remain lit even when the knob is turned sharply from the maximum to the minimum position.

The adjustment is performed with the burner lit, as follows:

- Turn the knob to the minimum position.
- Remove the tap knob.
- Turn the screw "A" to the correct setting with a screwdriver (fig. 21).

**For LPG, tighten the adjustment screw completely.**

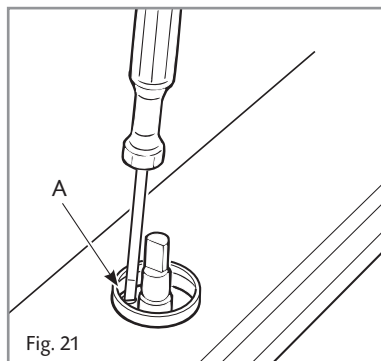

Fig. 21

## Lubrication of the Gas Taps

The operations must be executed by a qualified technician.

**IMPORTANT: All intervention regarding installation maintenance and conversion of the appliance must be fulfilled with original factory parts.**

**The manufacturer declines any liability resulting from the non-compliance of this obligation.**

## Mains Electricity Connection

**Incorrect installation may be dangerous and the manufacturer can not be held responsible.**

**Warning! This appliance must be earthed The manufacturer declines all responsibility for any problem caused by failure to observe this rule.**

THIS APPLIANCE MUST BE CONNECTED TO THE MAINS SUPPLY BY A COMPETENT PERSON, USING FIXED WIRING VIA A DOUBLE POLE SWITCHED FUSE SPUR OUTLET AND PROTECTED BY A 3A FUSE.

We recommend that the appliance is connected by a qualified electrician, who is a member of the N.I.C.E.I.C. and who will comply with the I.E.E. and local regulations.

The wires in the mains lead of this appliance are coloured in accordance with the following code:

**Green & Yellow = Earth, Blue = Neutral, Brown = Live.**

As the colours of the wires in the mains lead for the appliance may not correspond with the coloured markings identifying the terminals connecting to the fuse spur, proceed as follows:

- The wire which is coloured green and yellow must be connected to the terminal marked E (Earth) or coloured green.
- The wire which is coloured blue must be connected to the terminal marked N (Neutral), or coloured black.
- The wire which is coloured brown must be connected to the terminal marked L (Live), or coloured red.

**Note: Use a 3A Fuse**

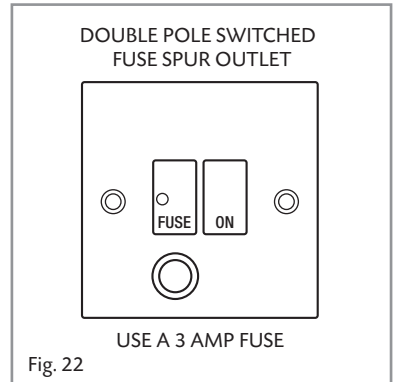

Assembly and electrical connection should be carried out by specialised personnel.

When installing this product we recommend you seek the help of another individual.

## Appliance Servicing

CDA provide a quality and effective after-sales service to cover all your servicing needs.

Please attach your receipt to this page for safekeeping.

Please help us to help you by having the following information available when booking a service-call:

1. Model type, make and model – see the product data plate.
2. Evidence of installation / purchase date
3. Retailer where appliance was purchased
4. Clear and concise details of the fault
5. Full address including postcode and any contact phone numbers

### **Contact Telephone Numbers**

CDA Customer Care Department

– Telephone: 01949 862012

– Fax: 01949 862003

– Email: [customer.care@cda.eu](mailto:customer.care@cda.eu)



Please contact our Customer Care Department, or for Service on the details below.